

8DO Digital Output Module

for the MOSCAD RTU

The 8 Digital Output module is an accessory to the MOSCAD RTU family that provides eight relay outputs that may be connected to, and used to control, on-site high-current electrical devices. Examples includes lighting circuits, pumps, and motors.

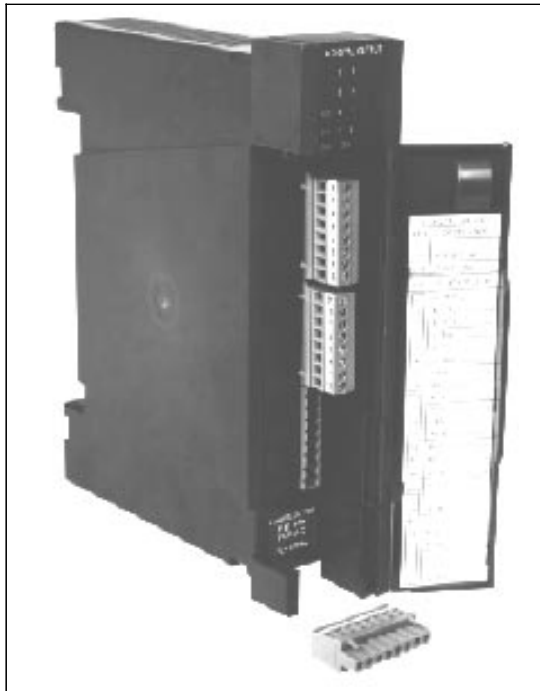

FEATURES/BENEFITS

Data Output

Under the control of the defined Application Program, the CPU module will move the current status of the data variables in the CPU module that are associated with the relays to the 8DO module via the motherboard. The 8DO module then opens or closes the relays according to the status of this data.

◆ *The application in the CPU module, using data obtained throughout the system, determines the state of the output relays.*

Electrically-Energized Relays

The 8DO module has eight high-current conventional relays. These relays have a single coil each. The relays remain closed for as long as their coils are energized.

◆ *This type of relay provides user control when it is mandatory that the relays open when power is lost or control otherwise disrupted.*

Activation Feedback

The 8DO module has secondary contacts on the relays that provide positive feedback that the relay has closed.

◆ *This feedback may be treated as digital inputs and incorporated into the Application when required.*

Packaging

The module is packaged in a plastic housing that plugs and locks into the motherboard. Wire connections (up to 14 ga. wire) are made to removable connectors on the face of the module. No jumpers, calibration pots, etc. are located on the module (any calibration is done electronically via software from the ToolBox program.)

◆ *Modularity allows the MOSCAD RTU to be easily expanded as system wants and needs change and makes field module replacement quick and easy.*



MOTOROLA

Specifications

Order	Plant Installed: V508 Field Installed: FLN2295
Relays	Number & Type: 8, electrically energized Contact Rating: 10 Amp @ 277 Vac; 10 Amp @ 30 Vdc
Output Protection	Per ANSI/IEEE C37.90.1-89: High Frequency SWC = 2.5 kV; Fast transient = 4 kV Per ANSI/IEEE C62.41: Class B2 = 4 kV/2 kA Per IEC 801-2, IEC 255-22: ESD Class 4 = 8/15 kV Per IEC 801-3, IEC 255-22-3: EMI Class 3 = 10 V/m Per IEC 801-4: Fast transient Level 4 = 2 kV Per IEC 255-4: High Frequency Class 3 = 2.5/1 kV; Impulse Class 3 = 5 kV
Diagnostic	20 LEDs: 8 for Outputs, 1 each for Module Fail and No Clock, 10 spare
Power	5 Vdc: 15 ma 12 Vdc: 5 ma (18 ma with LEDs on) plus 65 ma (max.; 44 ma typical) per energized relay
Environment	Humidity: 0-90% @ +50°C Temperature: -30 to +60°C

Typical Output Circuit

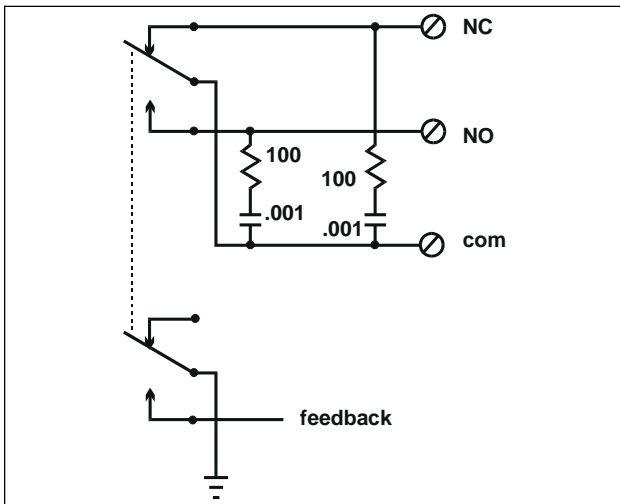

Connections Chart

Term	Function	Term	Function
1	K1 NO	13	K5 NO
2	K1 com	14	K5 com
3	K2 NC	15	K5 NC
4	K2 NO	16	K6 NO
5	K2 com	17	K6 com
6	K2 NC	18	K6 NC
7	K3 NO	19	K7 NO
8	K3 com	20	K7 com
9	K3 NC	21	K7 NC
10	K4 NO	22	K8 NO
11	K4 com	23	K8 com
12	K4 NC	24	K8 NC



Support Services

Wherever Motorola sells, our product is backed by service. Our products are serviced throughout the world by a wide network of company or authorized independent distributor service organizations. Specifications subject to change without notice.



Winner 1988



MOTOROLA

1301 E. Algonquin Road
Schaumburg, Illinois 60196
In the U.S. call: 1-800-247-2346
Outside the U.S. call: (708) 576-3107

©, and Motorola are trademarks of Motorola, Inc. ■ © 1994
Motorola, Inc. ■ Printed in U.S.A. ■ Produced
by Customer Communications. 36 USC 380
Motorola is an Equal Employment Opportunity/
Affirmative Action Employer